

GENERAL DESCRIPTION

The HP6050 series are ultra-low dropout, fast transient response, high current delivery, high PSRR CMOS LDO.

The quiescent current consumed by the HP6050 is typically 120uA over the entire input voltage range, making it attractive for consumer, networking applications that demand high output current. The HP6050 series are available in wide output voltage range from 1.2V to 3.3V. The HP6050 series offer thermal shutdown protection (OTP) and current limit functions, to maintain the stability of chip and power system at abnormal conditions. HP6050 uses trimming technique to guarantee output voltage accuracy within $\pm 2\%$.

The HP6050 series can choose the output current limit to be 500mA (minimum) or 1A (minimum) by alternating the LCON pin between "L" or "H". The HP6050 regulators are available in DFN1612-8L packages. Standard products are Pb-free and Halogen-free.

FEATURES

- Input voltage: 2.5V~5.5V
- Output range: 1.2V~3.3V
(Customized by every 0.1V step)
- Output current: 500mA/1A
- Dropout voltage: 65mV @ $V_{OUT}=2.8V$, $I_{OUT}=500mA$
- Quiescent current: 120 μ A Typ.
- PSRR: 80dB @ $f=1KHz$

APPLICATIONS

- Portables
- Set Top Box
- Computer, Graphic card
- Network communication equipment
- Others portable electronics devices

TYPICAL APPLICATION CIRCUIT

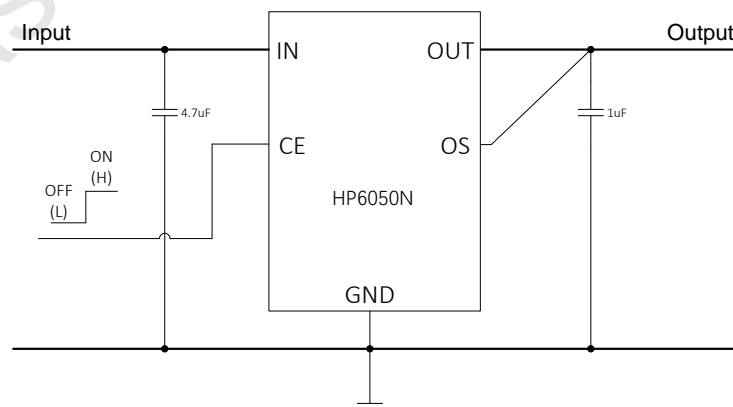
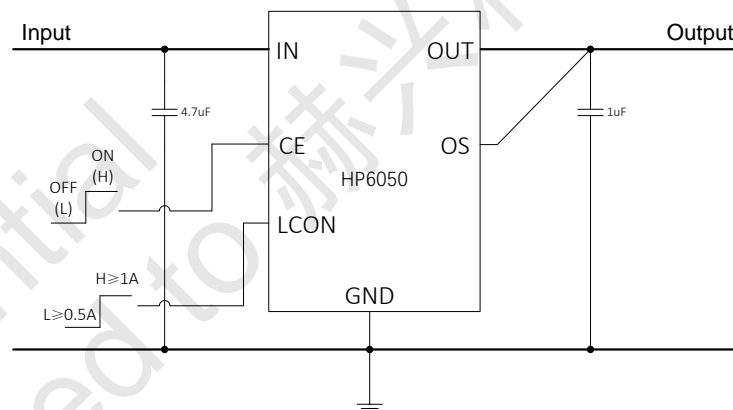

PIN ASSIGNMENT

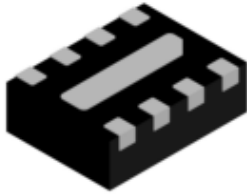

DFN1612-8L

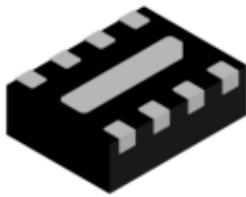

DFN1612-8L

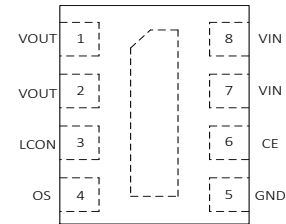

HP6050D8

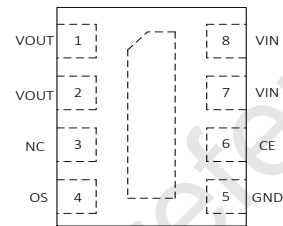

HP6050ND8

ORDER INFORMATION

PART NO	PACAKGE	CURRENT LIMIT	TEMPERATURE	TAPE & REEL
HP6050D8-xx	DFN1612-8L	LCON=H, $\geq 1A$ LCON=L, $\geq 0.5A$	-40 ~ +85°C	4000/REEL
HP6050ND8-xx	DFN1612-8L	$\geq 1A$	-40 ~ +85°C	4000/REEL

"XX": Fixed output voltages ranging from 1.2V to 3.3V.

PART NUMBER RULES

HP6050^[1]-^[2]

Code	Description
[1]	Package: D8: DFN1612-8L
[2]	Voltage version: XX: several fixed output voltages ranging from 1.2V to 3.3V Example: 33: 3.3V

MARKING DESCRIPTION:

DFN1612-8L:



"X": product code, here use "C" stands for "HP6050",
"D" stands for "HP6050N".

"Y": Internal Control Code.

"W": The week of manufacturing. "A" stands for week 1, "Z" stands for week 26, "a" stands for week 27, "z" stands for week 52.

"V": Output voltage code.

TYPICAL OUTPUT VOLTAGE CODE TABLE

VOUT	CODE	VOUT	CODE
1.2V	B	2.8V	M
1.5V	C	2.9V	N
1.8V	D	3.0V	G
2.5V	E	3.3V	H
2.6V	F		
2.7V	L		

PIN DESCRIPTION

PIN NO	SYMBOL	I/O	DESCRIPTION
1	VOUT	O	Output
2	VOUT	O	Output
3	LCON/NC	I	For HP6050, it's output current limit alternate Pin ("H" \geq 1A, "L" \geq 500mA) and NC for HP6050N
4	OS	I	Output sense pin, connect to output capacitor
5	GND	G	Ground
6	CE	I	Chip Enable, Active high
7	VIN	P	Input Power
8	VIN	P	Input Power

ABSOLUTE MAXIMUM RATINGS (Note)

SYMBOL	ITEMS	VALUE	UNIT
V _{IN}	Input Voltage	-0.3~6.5	V
V _{CE}	CE voltage range	-0.3~V _{IN}	V
V _{LCON}	LCON voltage range	-0.3~V _{IN}	V
V _{OUT}	Output Voltage	-0.3~V _{IN}	V
P _{DMAX}	Power Dissipation	0.625	W
R _{θJA}	Thermal resistance	165	°C/W
T _J	Junction Temperature	150	°C
T _{STG}	Storage Temperature	-55 to 150	°C
T _{SOLDER}	Package Lead Soldering Temperature	260°C, 10s	
ESD Ratings	HBM	8	KV

Note: Exceed these limits may damage the device. Exposure to absolute maximum rating conditions may affect device reliability.

RECOMMENDED OPERATING RANGE

SYMBOL	ITEMS	VALUE	UNIT
V _{IN}	VIN Supply Voltage	2.5 to 5.5	V
T _{OPT}	Operating Temperature	0 to 85	°C

ELECTRICAL CHARACTERISTICS

The following specifications apply for $T_A=25^\circ\text{C}$, $V_{IN}=V_{SET}+1\text{V}$, $C_{IN}=4.7\mu\text{F}$, $C_{OUT}=1\mu\text{F}$, $I_{OUT}=1\text{mA}$, $LCON=CE=V_{IN}$, unless specified otherwise.

SYMBOL	ITEMS	CONDITIONS		MIN	TYP	MAX	UNIT
V_{IN}	Input Voltage			2.50		5.50	V
V_{UV}	UVLO	VIN rising			2.05	2.25	V
V_{UV_HYS}		VIN falling			0.15		V
V_{OUT}	Output Voltage Range	$V_{OUT} \geq 1.5\text{V}$		-2		+2	%
		$1.2\text{V} \leq V_{OUT} < 1.5\text{V}$		-30		30	mV
ΔV_{LOAD}	Load Regulation	$V_{IN}=V_{OUT}+0.5\text{V}$	LCON="H" $1\text{mA} \leq I_{OUT} \leq 1\text{A}$		5		mV
			LCON="L" $1\text{mA} \leq I_{OUT} \leq 0.5\text{A}$		3		
I_Q	Quiescent Current	$I_{OUT} = 0$			120	160	μA
V_{DROP}	Dropout Voltage	LCON=0, $V_{IN}=V_{SET}$, $I_{OUT}=0.5\text{A}$ $V_{SET} \geq 2.5\text{V}$			65		mV
		LCON=1, $V_{IN}=V_{SET}$, $I_{OUT}=1\text{A}$ $V_{SET} \geq 2.5\text{V}$			130		
ΔV_{LINE}	Line Regulation	$V_{set}+0.5\text{V} \leq V_{IN} \leq 5.5\text{V}$ ($V_{IN} \geq 2.5$)				6	mV
I_{SHDN}	Shut-down Current	$V_{CE}=0\text{V}$			0.7		μA
$\Delta V_{OUT}/\Delta T_a$	V_{OUT} Temperature Coefficient	$25^\circ\text{C} \leq T_A \leq 150^\circ\text{C}$			60		ppm/ $^\circ\text{C}$
I_{SC}	Short Current Limit	$V_{OUT}=0\text{V}$	LCON="H"		115		mA
			LCON="L"		78		
V_{CEH}	CE logic high voltage			1.2			V
V_{CEL}	CE logic low voltage					0.4	V
PSRR	Power Supply Ripple Rejection	$V_{IN}=(V_{SET}+1\text{V})+0.2V_{p-p}$, $f=1\text{KHz}$, $I_{OUT}=30\text{mA}$			80		dB
e_{NO}	Output noise voltage*1	BW=10Hz to 100KHz $I_{OUT}=10\text{mA}$ ($V_{OUT}/V_{fb} \cdot \mu\text{VRMS}$)	$V_{OUT}=3\text{V}$		75		μVRMS
			$V_{OUT}=1\text{V}$		30		
T_{SD}	Thermal shutdown threshold				165		$^\circ\text{C}$
ΔT_{SD}	Thermal shutdown hysteresis				25		$^\circ\text{C}$
I_{REVMAX}	Reverse Current	$V_{OUT}=V_{OUT(SET)}+1\text{V}$, $EN=0$			11.5		μA
I_{OCP}	Over Current Protect	LCON="H", or HP6050N		1			A
		LCON="L"		0.5			
I_{OCPs}	Start Up Current Limit	LCON="H"	Power On Start up		600		mA
		LCON="L"	Current Limit		300		mA
$R_{V_{OUT_DIS}}$	Discharge resistance	$V_{IN}=4\text{V}$, $V_{CE}=0\text{V}$, $V_{OUT}=1\text{V}$			60		Ω

SYMBOL	ITEMS	CONDITIONS	MIN	TYP	MAX	UNIT
V_{REV_DET}	Detector offset voltage in reverse current protection mode	$V_{OUT}=V_{oset}-0.1V$; $EN=1$ V_{IN} from high to low $V_{REV_DET} = V_{OUT}-V_{IN}$		0.23		V
V_{REV_REL}	Release offset voltage in reverse current protection mode	$V_{OUT}=V_{oset}-0.1V$; $EN=1$ V_{IN} from low to high $V_{REV_REL} = V_{OUT}-V_{IN}$		0.07		V
V_{LCON_H}	LCON logic high voltage		1.2			V
V_{LCON_L}	LCON logic low voltage				0.4	V
I_{CE}	CE pull-down current			0.25	1	μA
I_{LCON}	LCON pull-down current			0.25	1	μA

Note1: Guaranteed by design

SIMPLIFIED BLOCK DIAGRAM

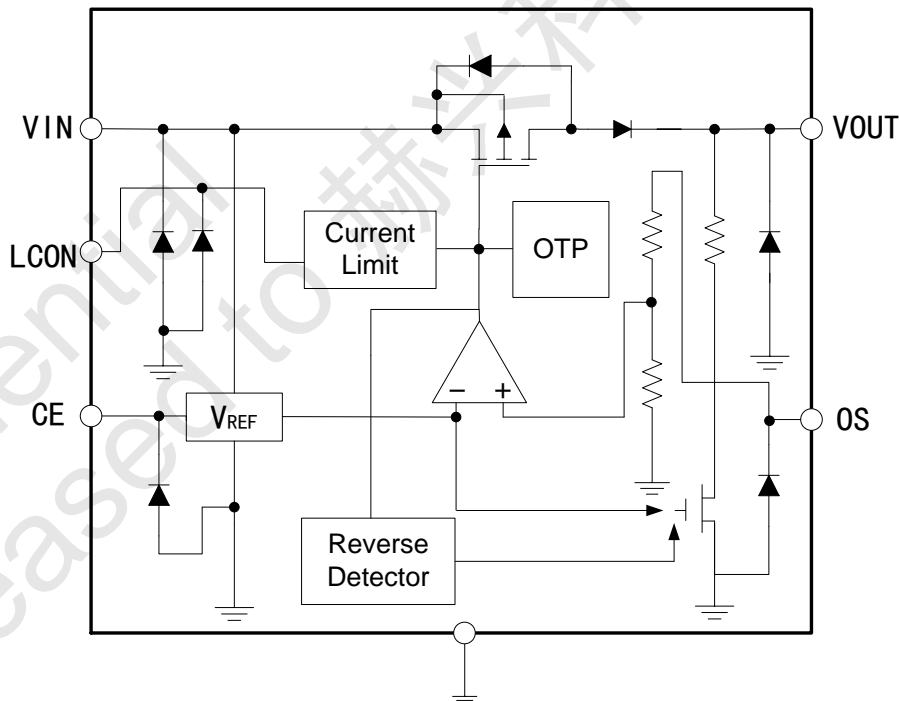

TYPICAL PERFORMANCE CHARACTERISTICS

The following specifications apply for $T_A=25^\circ\text{C}$, $V_{IN}=4.3\text{V}$, $V_{set}=3.3\text{V}$, $C_{IN}=4.7\mu\text{F}$, $C_{OUT}=1\mu\text{F}$, $I_{OUT}=1\text{mA}$, $LCON=CE=V_{IN}$, unless specified otherwise.

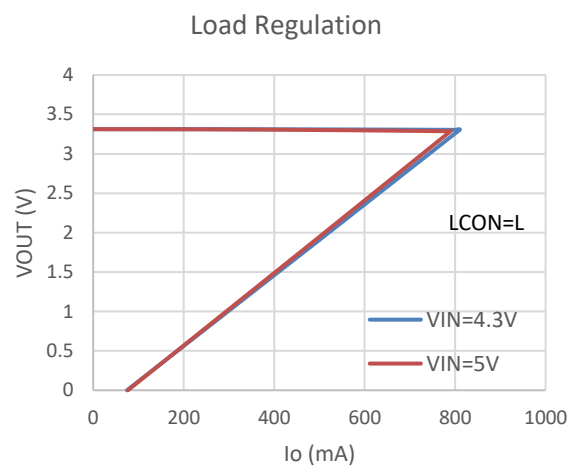
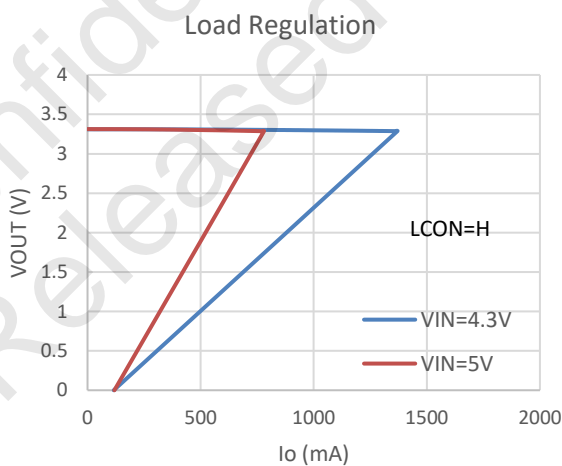
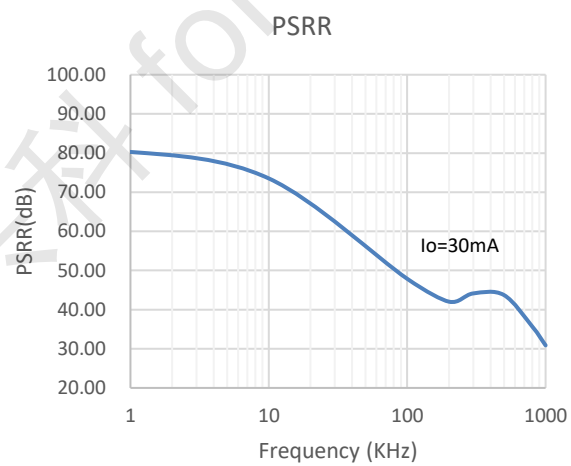
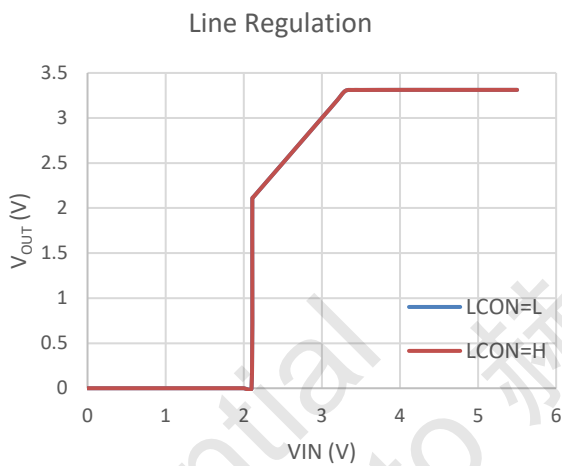
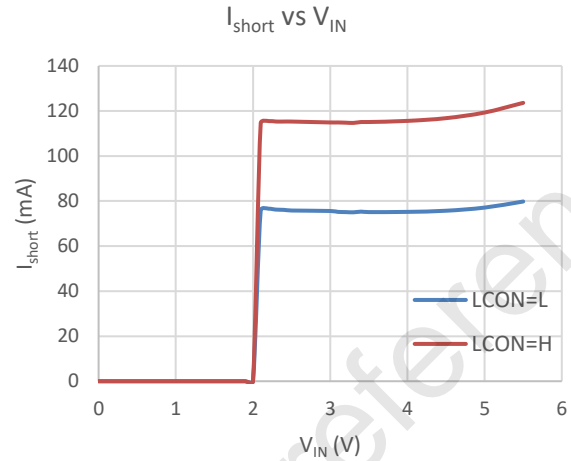
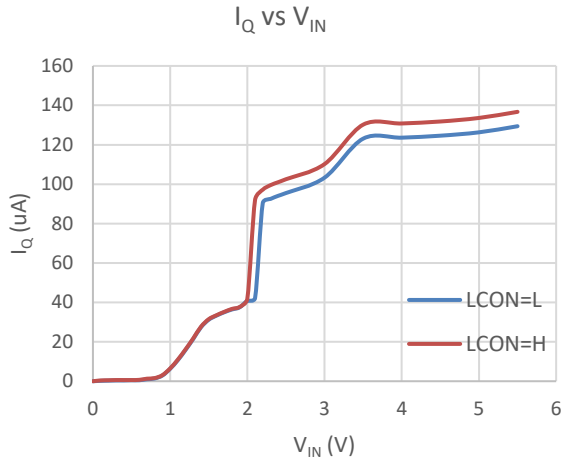

Figure 1 Line Transient Response

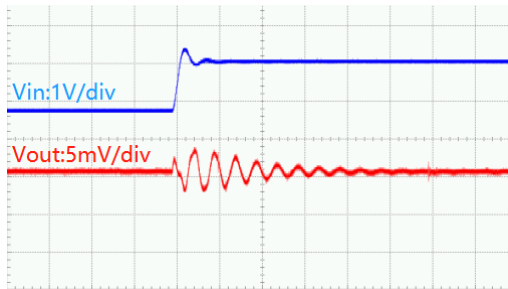

Figure 2 Load Transient Response

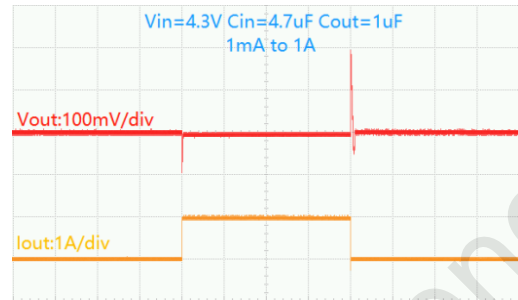

Figure 3 Power ON

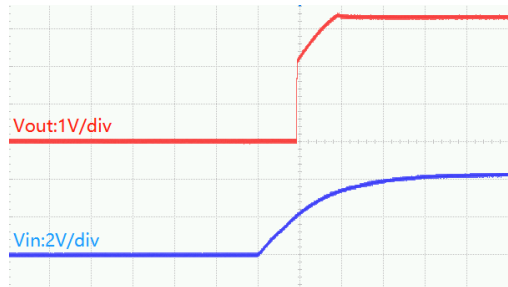
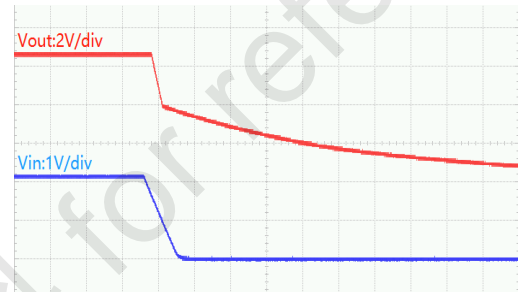

Figure 4 Power Off



Confidential
Released to 赫兴科 for reference

PACKAGE OUTLINE

Package	DFN1612-8L	Devices per reel	4000Pcs	Unit	mm
---------	------------	------------------	---------	------	----

Package Dimension:

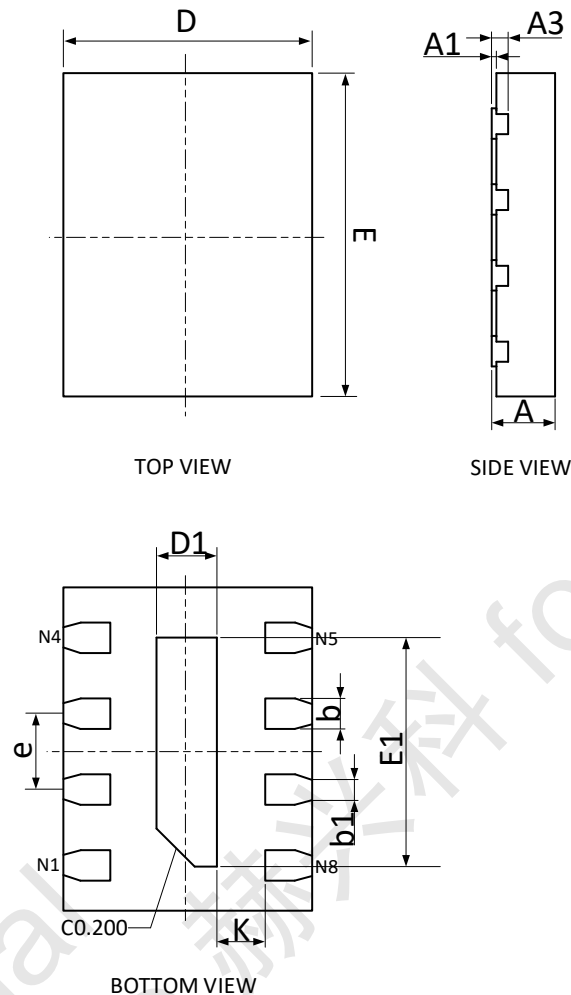

Symbol	Dimensions In Millimeters		Dimensions In Inches	
	Min	Max	Min	Max
A	0.320	0.400	0.013	0.016
A1	0.000	0.050	0.000	0.002
A3	0.102REF.		0.004REF.	
D	1.100	1.300	0.043	0.051
E	1.500	1.700	0.059	0.067
D1	0.200	0.400	0.008	0.016
E1	1.100	1.300	0.043	0.051
k	0.200REF.		0.008REF.	
b	0.130	0.230	0.005	0.009
b1	0.120REF.		0.005REF.	
e	0.400BSC.		0.016BSC.	
L	0.200	0.300	0.008	0.012

Revision History

Version No.	Date	Description
Preliminary	2021-10-22	Initial preliminary release
V0.1	2022-09-09	Add HP6050N version
V0.2	2022-09-19	Modify electrical characteristics & performance characteristics

Confidential
Released to 赫兴科 for reference